

Dog House

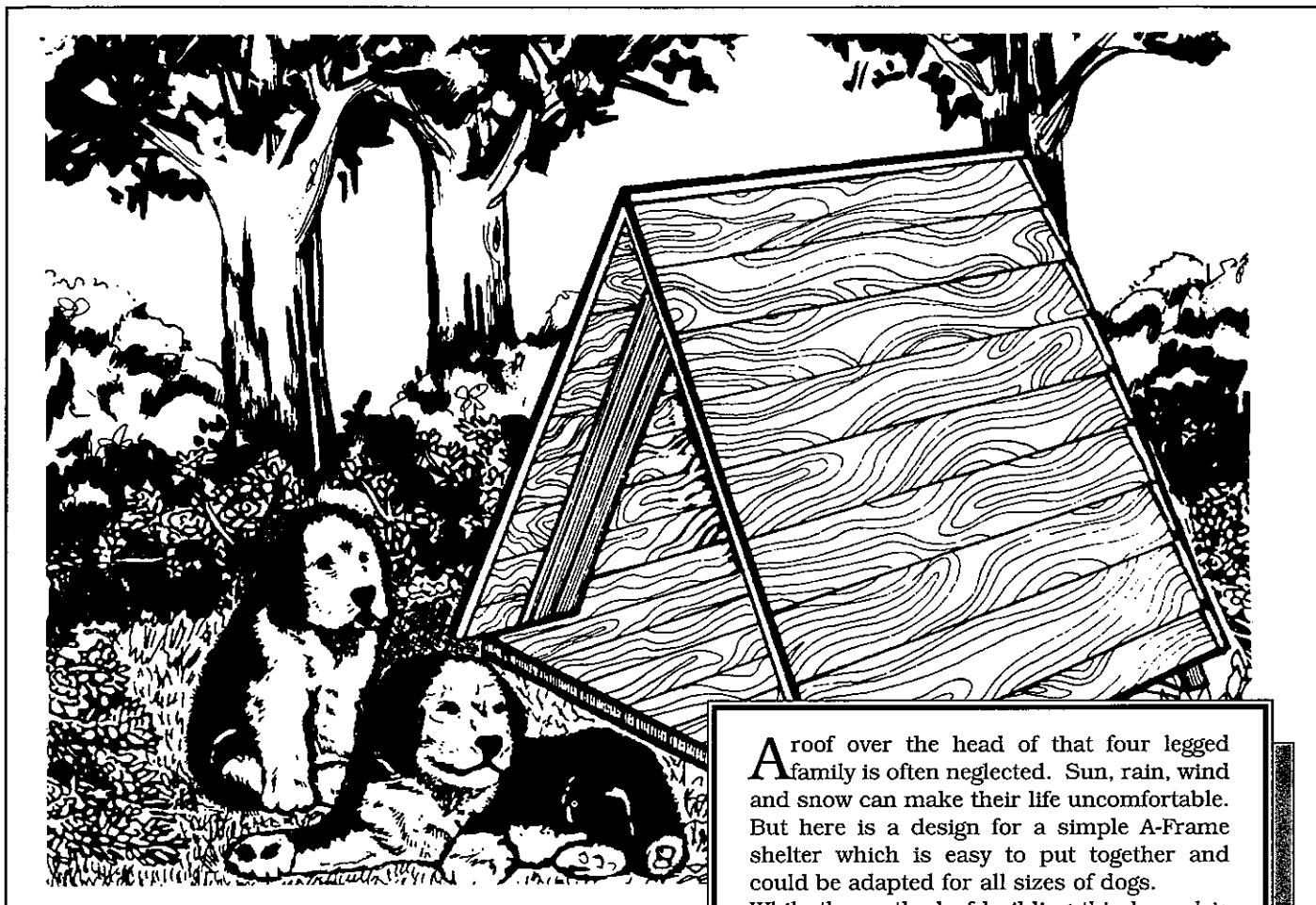

A roof over the head of that four legged family is often neglected. Sun, rain, wind and snow can make their life uncomfortable. But here is a design for a simple A-Frame shelter which is easy to put together and could be adapted for all sizes of dogs.

While the method of building this kennel is suitable for all sizes, the measurements given would be satisfactory only for a medium sized dog, about 400mm high.

If you wish to adjust the size to suit, your dog should not only be able to stand upright inside the kennel but should also be able to turn around before he/she curls up and lies down.

TOOLS YOU WILL NEED

- Hammer
- Saws
- Measuring tape/rule
- Carpenter's square and pencil
- Adjustable spanner
- Drill and bits
- 60 /30 set square

MATERIALS YOU WILL NEED

TIMBER

(For example only)

75 x 50mm, 6 pieces 1.2m* for two A-Frames (use durable timber).

75 x 25mm, Decking, or equivalents, 16 pieces 1.2m* (for flooring)

Scandinavian Pine Cladding* in 1.2m lengths (22 lengths should be sufficient for overall height of wall/roof and the end walls).

*Consult your TABMA merchant for suitable available materials and how these can be ordered.

HARDWARE

4/125 x 9mm Galvanised cup head bolts, nuts, washers.

100/50 x 2.8mm Galvanised flat head nails.

75 x 75mm x 1.2m length of zincalume angle as ridge capping OR

1.2m length of aluminium dampcourse.

12/12 x 3.2m Galvanised round head, metal thread, screws.

▼ **STEP BY STEP** ▼

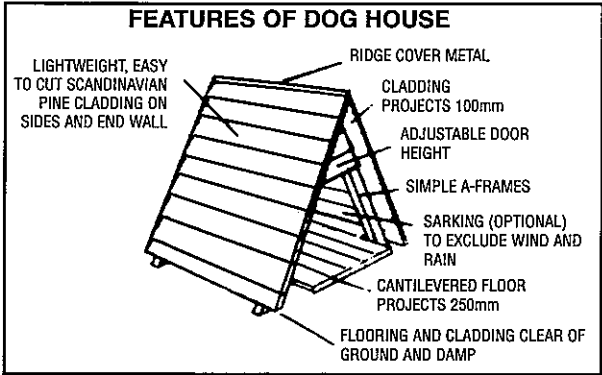

1 CUT A-FRAME PIECES. From the 1.2m lengths of 75 x 50mm timber, cut four A-Frame legs (A) to this pattern using the 60 /30 set square to mark the angles shown.

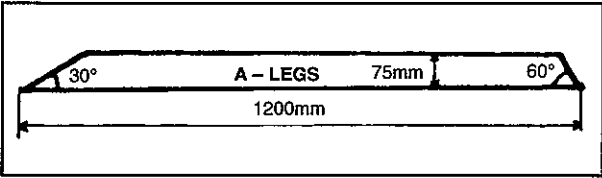

2 CUT FLOOR PLATE. From the remaining two lengths of 75 x 50mm pieces, cut two floor plates (B) to pattern below, using the 60 /30 set square to mark the angles shown.

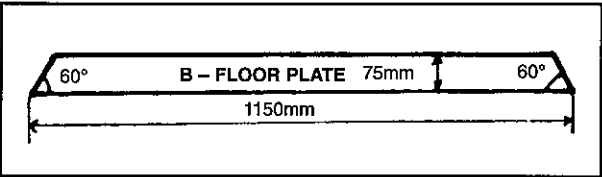

3 CUT TWO GUSSET PLATE. From a piece of Scandinavian Pine or other flat sheet material cut two gusset plates (C) to the pattern below using the 60 /30 set square to mark the angles shown.

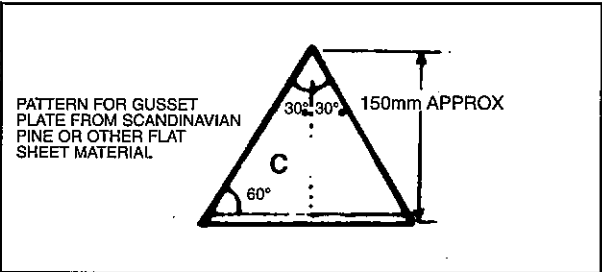

4 ASSEMBLE A-FRAMES. Using two of the legs (A) cut in (1) and a floor (B) as in (2) and gusset plates (C), assemble and fix components to make two A-Frames as in sketch below.

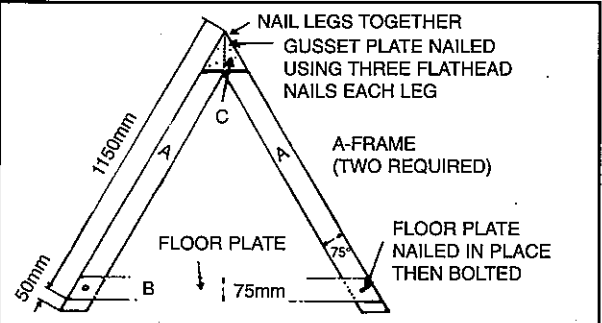

5 CUT FLOORING. From the flooring material, cut two short boards for side pieces each 900mm long. Cut two boards approx. 950mm length sufficient to cover the floor plate, allowing boards to be fixed closely together.

6 FIX FLOORING. (a) Select one of the assembled A-Frames and fix flooring square to floor as shown in plan diagram using two nails at each board - pre-drilling nail holes at end of board.

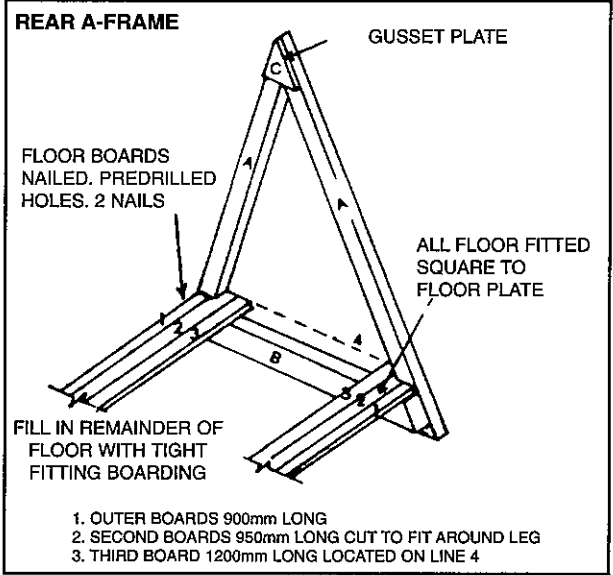

7 FIX FLOORING. (b) To the remaining A-Frame fix the floor boards to the floor plate as shown in diagram, similarly pre-drilling nail holes at end of boards.

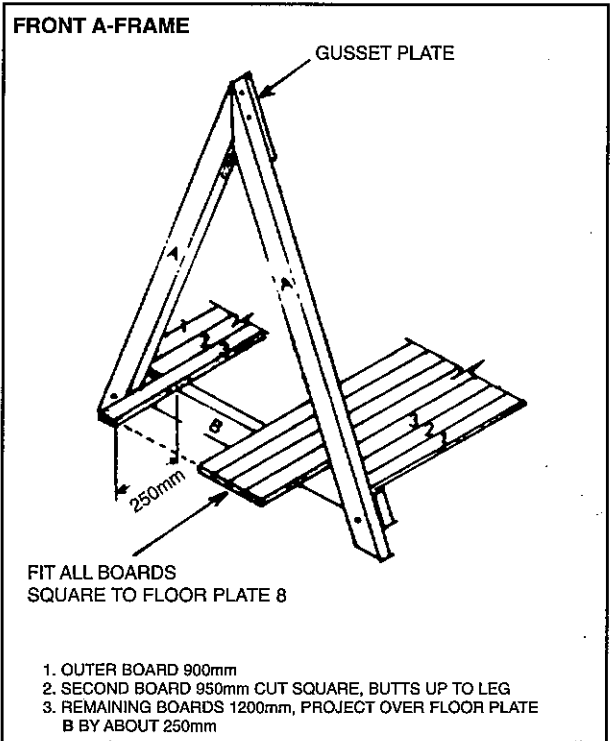

8 CUT AND FIX SIDE CLADDING.

(i) Cut lengths of cladding to 1200mm lengths. Commencing with top of (A), temporarily fix one board square to (A) legs allowing projection of approx. 100mm both front and back beyond A-Frame. Use two nails on each end of the cladding piece. (Note: spacing at top between frames should be exactly the same as that at flooring level, i.e. 900mm.)

(ii) Sarking of building paper/heavy polythene is suggested. Fix this to open side by stapling or light tacking with cut tacks or similar, then permanently fix a top cladding piece to this covered side, using two nails each leg. To complete this sarked side, continue fixing cladding sufficient to cover exposed ends of floor plates (B).

(iii) Remove temporary top cladding piece and fix sarking to second side. Fix cladding to second side, as in (ii) above.

(Note: Allow sarking to slightly sag between frames and extend well over the edges of the outer floor boards.)

9 CUT AND FIX END CLADDING. Cut first piece of end cladding to shape given for gusset plate. (Step 3.) Then continue cutting cladding pieces as required in diagram (See step 10).

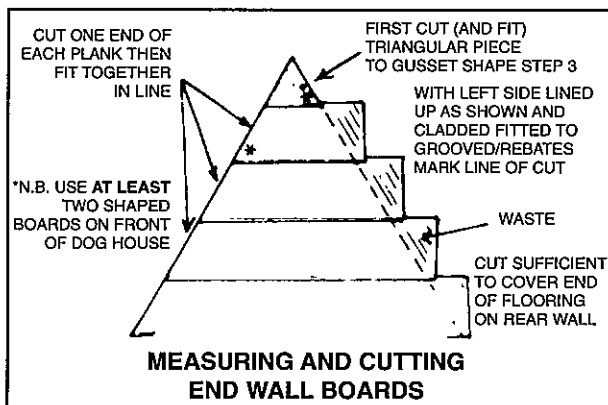

10 FIX FRONT CLADDING. Fix at least two pieces of angle cut cladding to front of structure. This could be increased so as to reduce height of door, depending on size of dog.

11 FIX REAR CLADDING. Loosely fix shaped piece of selected sarking to outside end frame, so as to drape outside edges of flooring. Commencing with topmost piece, cut and nail fix sufficient cladding to cover exposed ends of decking floor. Allow clearance between end cladding and ground line of at least 50mm.

12 CUT OFF, SAND OR SMOOTH to common line the exposed ends of cladding, similarly round off and smooth projecting floor boards.

13 PRIME COAT DOG KENNEL. Apply recommended prime coat(s) of selected coating system to exposed timbers including under flooring.

14 CUT AND FIX RIDGE CAPPING. Cut 1200mm length of selected ridge capping. Fix to ridge using zinc plated, round head, self tapping metal thread screws in pre-drilled holes. Prime coat ridge capping.

15 COMPLETE PAINTING. Apply final coats of selected paint/stain finish and allow several days to thoroughly dry and all odours to evaporate before introducing dog to new residence.

16 LOCATING DOG KENNEL. Locate dog kennel so that the doorway is protected from the worst of the rainy/windy weather. Place legs so that the floor would slightly slope down towards the doorway. We suggest you put legs on bricks rather than on grass or soil.

OTHER SIZE DOG KENNELS

The size of the dog kennel can be increased to fit your dog by using longer legs to the A-Frame and longer floor plates. However retain the angles of 60 /30 where indicated on frames and on the end cladding.

Supplied by