



# Garden Screens



QUALITY • SERVICE • INTEGRITY

Timber and Building  
Materials Association  
(NSW) Limited

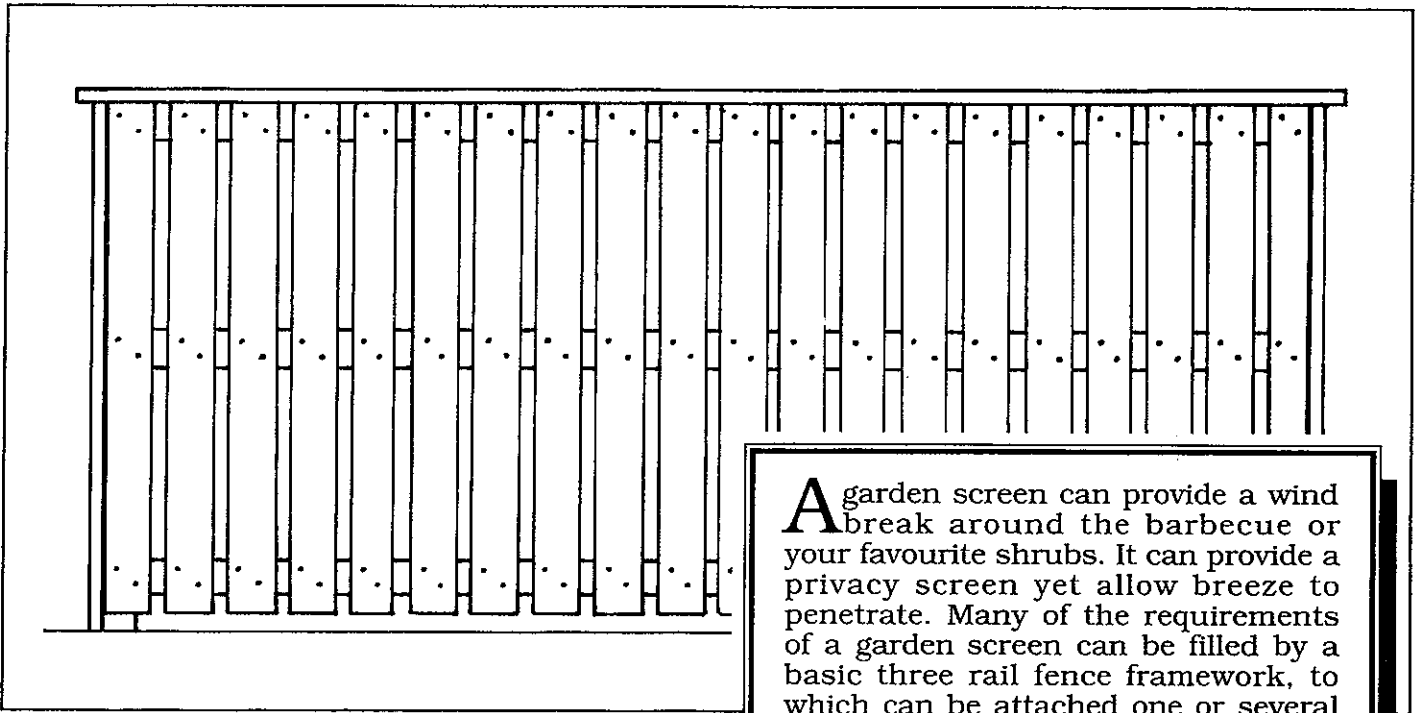

A garden screen can provide a wind break around the barbecue or your favourite shrubs. It can provide a privacy screen yet allow breeze to penetrate. Many of the requirements of a garden screen can be filled by a basic three rail fence framework, to which can be attached one or several of the readily available materials. For a real, warm, solid, timber screen you could fix conventional weatherboards, vertical boarding or palings, shiplap planking or similar and coat them with one of the many timber colour stains or paint type finishes.

## Tools you will need

- Saws
- Hammer
- Measuring Tape and pencil
- Carpenter's square
- String line and level
- Spirit level, plumb bob is useful
- Drill and bits
- Spanner
- Post hold digger (preferred) or other tools for digging post holes.

## Materials you will need

### TIMBER

#### POSTS:

◆ 100x75mm x 2.4m

Highly durable timbers (order sufficient posts for fence according to your plan). The timber merchants will provide timber of standard length from which you can cut posts to lengths required.

#### RAILS:

◆ 75 x 50mm

Durable timber. Order rail lengths to fit two (or more) panel lengths of fence, number as needed for total length of this three rail fence. Your timber merchant will provide timber of standard lengths from which you can cut rails to required lengths.

#### CAP RAIL:

◆ 150x25mm

Lengths to suit fence layout, durable timber, for screen capping rail.

### HARDWARE

- 150 x 9mm Galvanised round head bolts.
- Nuts and washers. One bolt at each rail/post junction is suggested.
- 50 x 2.8mm Galvanised flat head nails, for fixing facing to screen frame.
- 75 x 3.2mm Galvanised nails for temporary fixing of nails in place.

## SOME ALTERNATIVE SCREEN FACINGS

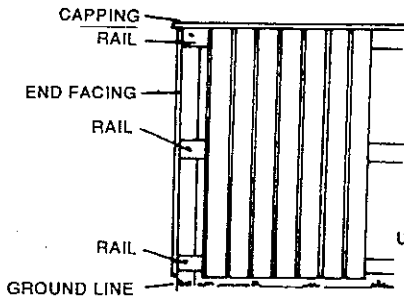

**A: CLADDING FIXED VERTICALLY**

**USES:** WIND BREAK, PRIVACY SCREEN, SOME SOUND BARRIER.

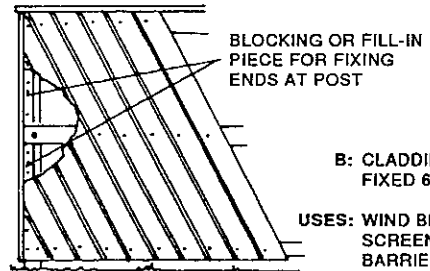

**B: CLADDING AS IN A FIXED 60° ANGLE**

**USES:** WIND BREAK, PRIVACY SCREEN, SOME SOUND BARRIER.

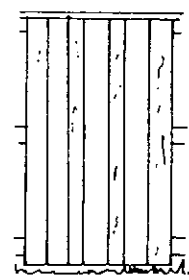
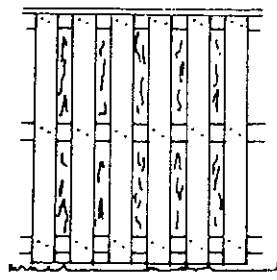
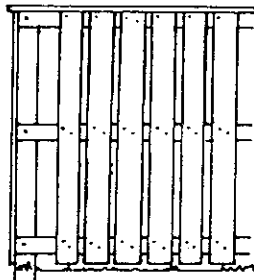
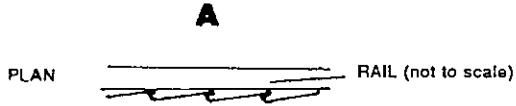

**C: SPACED PALINGS OR 150 X 25mm PLANK, VARIABLE SPACING.**

**USES:** PRIVACY, ALLOWS BREEZE, PLANT TRELLIS.

**D: SPACED, OVERLAP, TWO-SIDED SCREEN, PALINGS, ETC AS FOR 'C'.**

**USES:** PRIVACY, ALLOWS BREEZE, PLANT TRELLIS.

**E: OVERLAP, CLOSED, SINGLE SIDE, PALINGS, ETC., AS FOR 'C'.**

**USES:** PRIVACY, WIND BARRIER, NOISE BARRIER.

**F: SHIPLAP (OR CHANNEL), SPECIAL PROFILE, FIXED VERTICALLY, VARIOUS WIDTHS.**

**USES:** WIND BREAK, PRIVACY, SOME SOUND BARRIER.

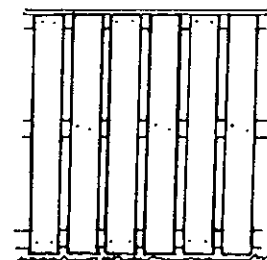

**G: WIDE VERTICAL PLANK PATTERN USING SHEET MATERIAL. E.G. HARDIPLANK SMOOTH OR WOODGRAIN, WEATHERTEX OR EXTERIOR GRADE PLYWOOD.**

**USES:** PRIVACY SCREEN AND PLANT TRELLIS, ALLOWS BREEZE.

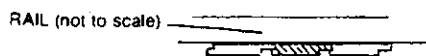

**Disclaimer:** While the Timber and Building Materials Association (NSW) Limited (TABMA) and its members believe this publication is an invaluable guide to this project, the Association cannot guarantee that every statement is without flaw. Therefore, the Association and its members hereby disclaim all liability for errors or omissions of any kind, whether they be negligent or otherwise, or for any loss, damage or other consequence which may arise from any person relying on information stated in this publication.

This brochure was prepared with the assistance and co-operation of the Timber Development Association NSW Ltd.

For further advice telephone the TDA Timber Advisory Service on (02) 9360 3088

Copyright Owner:  
Timber and Building Materials Association (NSW) Limited

**Supplied by**

## Timber Selection

Because garden screens are exposed to the elements and posts in particular are in ground contact the choice of timbers must be restricted to those which are durable in severe conditions. For in-ground posts very durable timbers are preferred which usually restrict choice to selected hardwoods, cypress pine, plantation pine treated for in-ground use. For other garden screen components, exterior above ground durability is desirable but a wider range of timbers is suitable. **CONSULT YOUR TIMBER STOCKIST ON WHAT IS AVAILABLE AND SUITABLE FOR THIS PROJECT.** The timber can be dressed-all-round (DAR) to a smooth surface or in rough sawn condition. Both seasoned and unseasoned timber may be used.

## Design of Garden Screen

A simple screen consists of posts embedded firmly in the ground, and the rails. Two or more rails can be used depending on the height required. Posts are normally spaced evenly along the fence line. A basic three rail design is described with an overall height of about 1650mm. Several suggestions are made for screen cladding.

The screen should be located to give the effect desired

## Locating the Garden Screen

whether this be to provide a windbreak, a privacy screen between road and house or around barbecue, etc. It is useful to fix one or both ends of the screen to an existing rigid structure (house or garage, etc) so as to provide some bracing. Alternatively, two intersecting screens can provide bracing to each other.

## ▼ STEP BY STEP ▼

**1 Planning screen:** Measure the length of screen required and calculate the number of posts needed. **It is advisable to draw out on paper a sketch of the screen layout.** Posts should be no more than 2.4 metres apart giving panels of equal length where practical. Rails should run over two panel lengths of the screen, again where practical, but should be 'staggered' on posts so that joins of all three rails do not occur on the same post. With the aid of this planning diagram you will be able to calculate or count the number of posts required and the number of lengths of railing needed and plan how rails can be fitted.

**2 Preliminary work:** If possible in the early stages of preparation there is benefit to be gained by treating the base or bottom portion of all posts with proprietary water repellent fungicidal mixture. It is preferable to actually soak that below-ground portion of post in the treating fluid. However, if this is not practical, then three heavy brush coats applied on the portion of post which will be below ground, particularly all end grain sections, and about 100mm of the post above ground, is one compromise alternative. Allow the brush coats to dry before proceeding with setting-out the screen.

**3 Setting out posts - Where to start:** Corner and finishing posts should be erected first. The centre of the posts should be positioned over the line of the screen. Dig post holes 750mm deep, provide tamped but free draining material at bottom of hole.

The tops of these posts should be set at the required height of the fence above the ground.

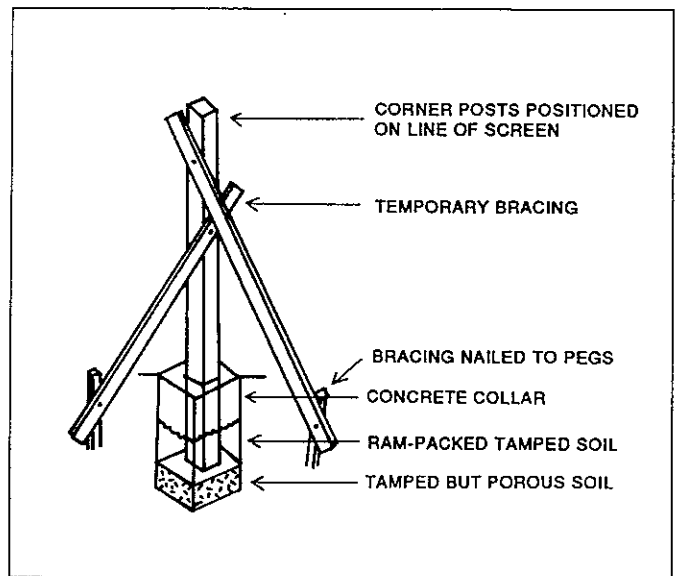

For our example, this height is 1650mm above ground line. Firmly brace both the corner and finishing posts as shown in sketch so that they are vertical and exactly located on centre line of screen. Tamp in soil around braced posts up to about 300mm from ground line.

With both end posts braced in position run a string line from corner to corner attached to the face (front) side of the posts (see sketch).

**4** Using a steel measuring tape, the length of the screen may now be divided into panels (the distance between two adjacent posts). The panel widths should not exceed 2.4 metres and wherever possible should be adjusted to increments of 300mm (the basic length module used by the Timber Industry). Thus rails would be cut from standard lengths with minimum wastage. However, timber should be ordered in lengths which enable rails to cover (at least) two panelling lengths.

*Example: A screen 10 metres long, 10m ÷ 2.4m = 4.2 panels approximately. To assist in ordering and for better appearance we would suggest 5 panels at 2.0 metres between centres of posts so that rail timber would be ordered in minimum 4.2m lengths.*

**5** The remaining post hole centres can now be marked with all pegs driven in the ground (i.e. 2.0m apart in our example) using the straight edge and spirit level method or plumb-bob method, shown in the sketch, to locate centres of posts.

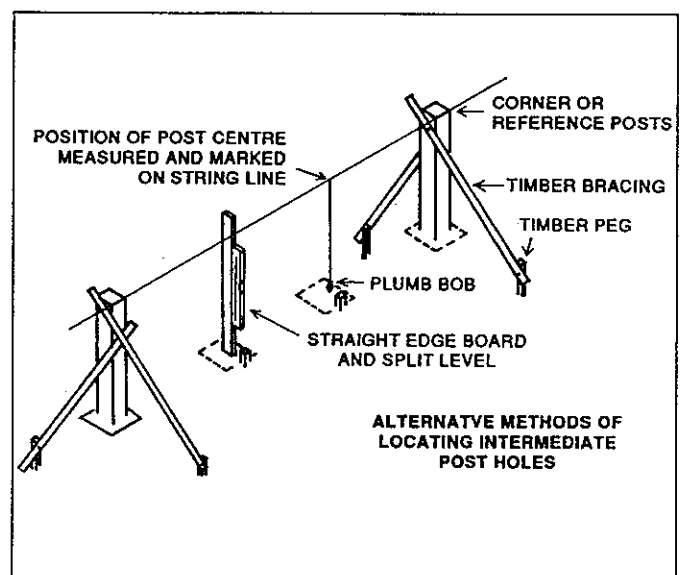

**6 Excavate post holes:** Excavate post holes to 750mm depth, accurately centred on pegged point. **Note:** You should devise some method of allowing water to drain away from bottom of posts. In free draining sandy soil this is not a problem, but in clayey soil you could set the post on a tamped layer of free draining material like gravel, pebbles, ashes, etc.

**7 Mark position of rails** on posts as indicated in this sketch. Gap between the bottom rail and ground line can be varied to suit your design. Rails spread evenly up the post give more acceptable appearance.

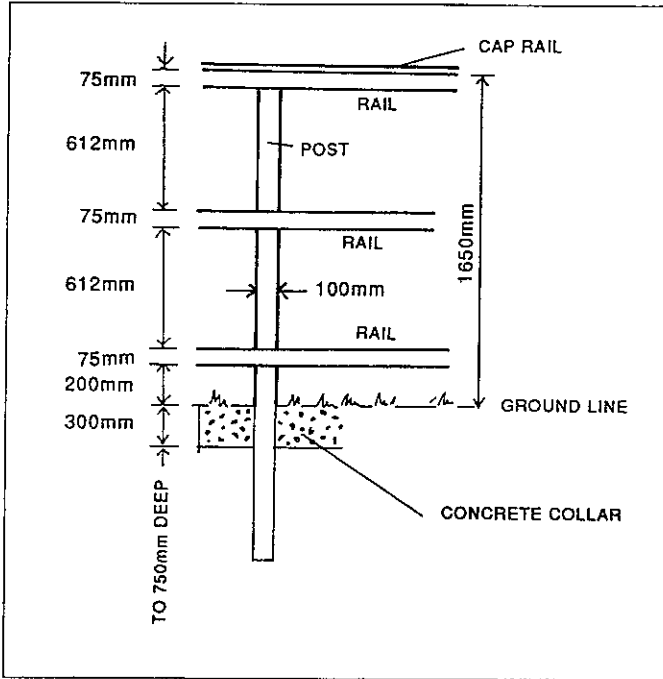

**10 Locate rails** in position on the posts by fastening them with one nail per post until all rails are in place. Follow the jointing pattern shown in Step 8 which avoids joining all rails on the same post. Butt joints should be located on centre lines of posts and all ends of rails should be primed/sealed before jointing is completed.

**11 Check alignment** of posts by string line and run of rails by eye and adjust if necessary, then complete fixing rails using one bolt at each post. Where butt joints occur careful drilling of bolt holes in ends of rails is required.

**12 Complete the consolidation of posts** in holes using a deep concrete collar for each end post and a shallow concrete collar around all other posts up to ground line. A formed up box or continuous concrete footing at ground level (perhaps a mowing strip) could be put in as collar(s) if desired.

**13 Prime coat screen framework** using exterior grade finishes as required. We recommend that all end grain of rails and posts be thoroughly primed or sealed with water repellent finishes.

**14 Cut and fix cap rail:** Cap rail 150 x 25mm is cut in long lengths and joined with butt join over posts. Use pre-drilled holes at joints but nail cap rail to topmost rail using nails at 500mm spacing along top rail. Allow for capping to project 15mm beyond face of selected cladding. We suggest cap rail be rounded off on long edges and primed coated/sealed with selected coating system, **before** fixing in place.

**8 Locate the posts in the holes** but do not yet attempt to fill in. Instead remove soil or fill hloe to give each post the desired height above ground as set by the string line.

For a sloping screen, a string-line contour can also indicate the angle at which tops of posts could be cut. Firmly tamp soil around post to about 450mm depth, ensuring that post is vertical and located correctly, using string line and spirit level.

**9 Cut rails to required lengths** as indicated in sketch. That is, the first and last rails in each line have allowance for end posts thickness but thereafter all rails are double or more panel lengths and butt-joined at mid-point of posts. In our example (see step 4) dimension 'P' should be standard double post spacing of  $4.0m + 50mm^* = 4050mm$ . **Note** that with adequate planning, rails of three panel length could be used, but avoid putting butt joints in all rails on the same post if possible.

(\*50mm is half the width of 100 x 75mm sawn posts)

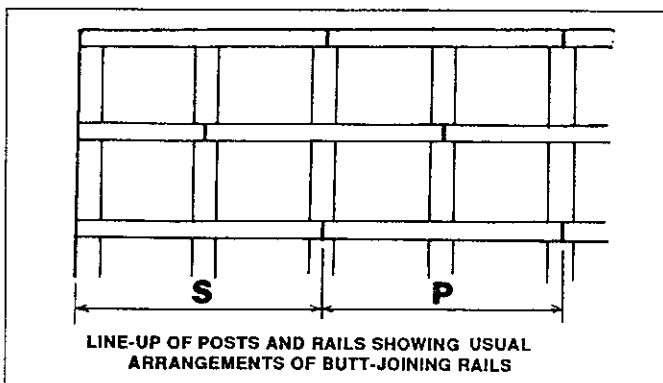

LINE-UP OF POSTS AND RAILS SHOWING USUAL ARRANGEMENTS OF BUTT-JOINING RAILS

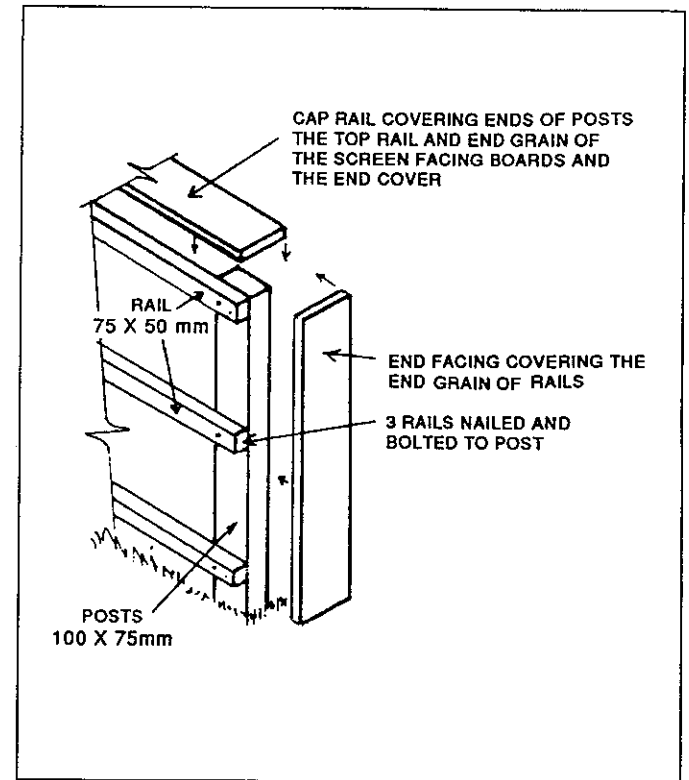

**15 Fix cladding.** Fix to the completed framework the selected facings or cladding, **Illustrations of several possible facings are given on last page.** Fix bottom edge of all facings clear of ground or concrete footings. Fit top of facing close to cap rail or within groove of pre moulded rail if used.

**16 Finishing:** We recommend that all timber facings be painted or stained or coated with **exterior** grade finishes to your choice. In many cases it is preferable to give boards at least one prime/seal coating **before** fixing, particularly where there are overlapping profiles or designs.

## E. Cladding and Roofing

With the frame erected and adequately braced, attachment of the cladding chosen can proceed but the procedure will depend on which material you have chosen

**Roofing:** rigid, hail resistant roof sheeting is recommended for the greenhouse and the manufacturers data sheets and instruction leaflets should be followed with regard to fixing details, overlap, etc.

**Wall Cladding:** many alternative clear/transparent materials or systems could be used - glass panels in metal channels, fibreglass mesh/shadecloth, corrugated FRP (Alsynite or similar) UV resistant PVC, acrylic or polycarbonate products and many timber cladding products would be suitable for the bottom 600mm - 900mm of each wall.

## F. Ventilation and heating and shading for Greenhouse

A greenhouse is intended to provide a protected and controlled atmosphere for growing plants.

Depending on the climate conditions you may need to provide ventilation controls - perhaps opening shutters in door and end wall or under-eaves flaps or gable ventilators.

If your greenhouse needs heating to carry the growing plants through winter weather, then some additional sealing of gaps in transparent cladding and roof may be necessary. A greenhouse to these dimensions could probably be warmed overnight by a typical heater fan unit provided adequate electrical safety precautions are followed. However, for severe winter weather, we suggest you consult the heating section in publications about greenhouse design and devise a suitable system for maintaining an adequate temperature within the greenhouse. Some greenhouses may also require provision of movable shading - shade cloth on rollers or removable panels - to reduce the effect of hot summer sun.

### Hint for under-eaves ventilator/sealing flap

- 1 Fix to bottom chords of roof truss adjacent to the top plate a timber cleat about 50mm x 25mm x length of roof.
- 2 Using corrosion resistant hinges, spaced about 900mm attach timber flap 75mm x 25mm to this timber cleat.
- 3 Fit flap catch at chords as required.

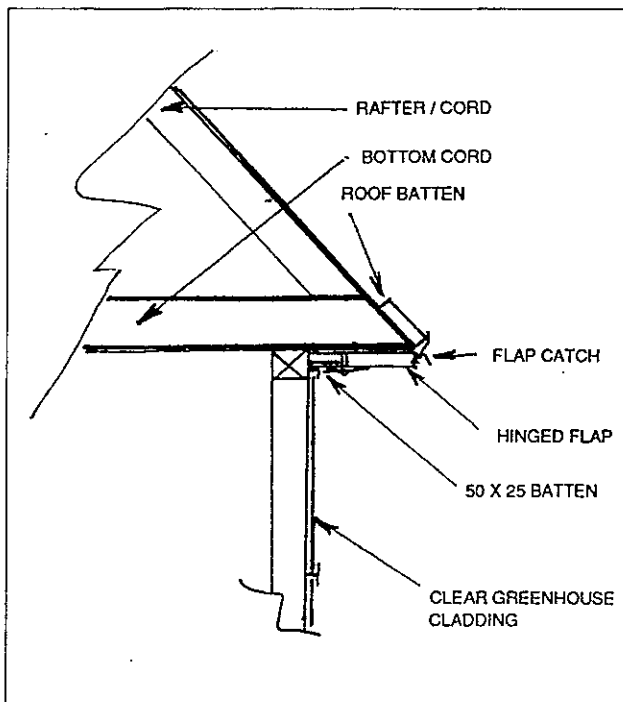

## G. Shadehouse Covering

Traditional shadehouses would use spaced timber lath or battens or wire netting and interwoven tree branches. In present day much of this heavy shading would be replaced by woven shade-cloth, selected according to the amount of shade required. Under certain circumstances a combination of shade-cloth and, say, timber lattice may be desirable - the lattice providing a relatively robust or strong covering where needed.

### SOME ROBUST TIMBER WALL CLADDING FOR SHADE HOUSES

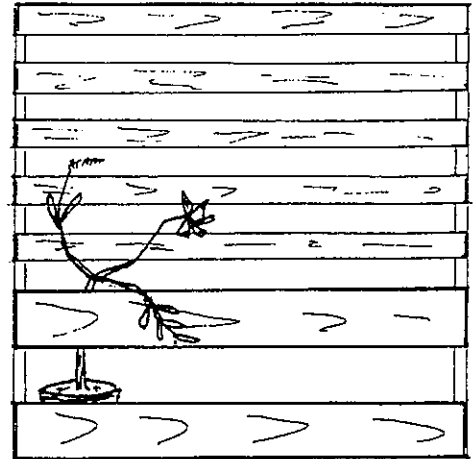

LATH OR PLANK. SELECT WIDTH THICKNESS AND SPACING TO GIVE SHADE AND PROTECTION.

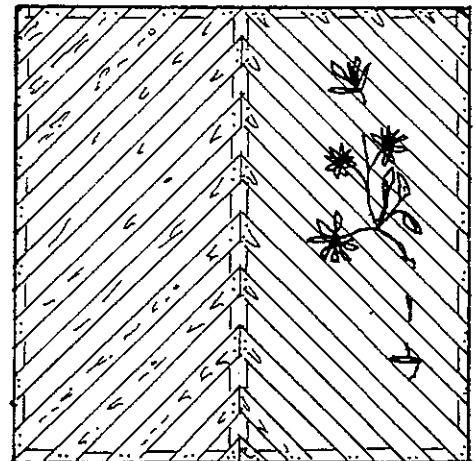

ANGLED LATH OR PLANK. SELECT WIDTH AND SPACING AS REQUIRED.

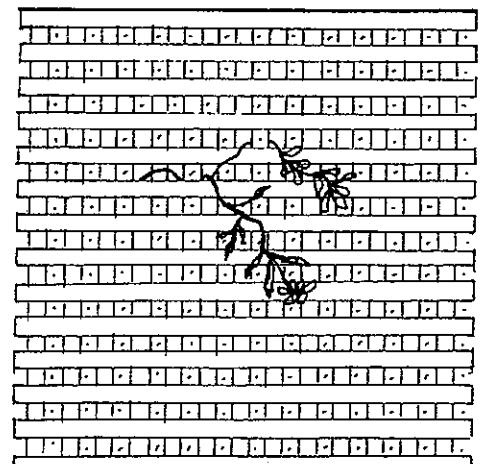

LATTICE. SEVERAL PREFABRICATED TYPES AVAILABLE OR BUILD ON - SITE