

Timber Floor Additions

Timber strip flooring often referred to as Tongue and Grooved (T & G) flooring boards is usually fixed after the added room is closed up; that is, the roof, walls and windows are in place. The intention is to keep the floorboards protected from inadvertent wetting by rain, surface damage etc.

A common practice is to loosely fit the majority of the floor, cutting as required to length and joining over joists and then laying the boards in place but turned upside down. This preliminary cutting and laying of the flooring not only provides a working platform but also enables the boards to be 'conditioned' to the environment before they are finally fixed in place after other internal works are completed - ceilings, wiring etc. etc. Here is an outline of the procedures in putting down a timber strip floor in a small addition.

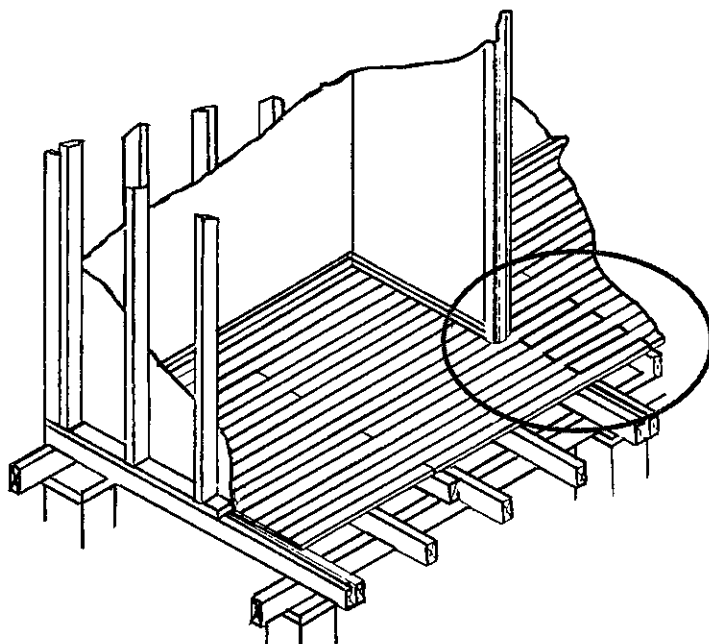

(vi) **Quality:** Discuss with your stockist and order sufficient for area plus about 10% cutting allowance in random lengths. If selected lengths are ordered (i.e. all boards are, say 3m length which just fits the room) then wastage allowance could be reduced even further.

▼ STEP BY STEP ▼

1 ESTIMATING QUANTITY:

(a) Measure length and breadth or width of the room in metres and calculate area of the floor in square metres

Length (m) x Width (m) = Floor area (m²)

(b) The width of T & G floorboards (in NSW) is quoted as the width of the sawn board before all machining and planing operations. To calculate the quantity of board required for your job you will need to know how much actual 'cover' you will get from the selected flooring timber. This 'cover' should be discussed with your timber stockist when selecting the timber species.

2 ORDERING T & G FLOORING:

The order which you will place with your timber stockist should state:

(i) **Grade:** Standard (for covered floors), or Select (for polished, clear finish).

(ii) **Timber Species:** Specify species according to requirement, colour, etc.

(iii) **Size:** T & G, width x thickness (e.g. 75 x 25mm) but also quote expected 'cover'.

(iv) **Ends:** Normal (ends) or end-matched.

(v) **Lengths:** Random lengths, or selected lengths.

3 STORAGE AND CARE: Flooring boards are usually seasoned before delivery so every care should be taken to maintain the boards in good order and condition before fixing. Floorboards on receipt should be stacked flat under cover, protected from rain and sun. After the new addition has been closed up (i.e. windows, exterior wall cladding and roofing are fitted) flooring could be loose stacked under this cover until required.

4 CUTTING DOWN: When all other necessary work has been done – for example, access doorways cut through existing walls, preliminary wiring roughed in, plumbing roughed in, etc. the flooring joists can be covered with the new floor boards, these being cut to bring end joints over the centre of joists, sawing off square but slightly under-cut to make a good joint. As this cutting is done, boards are turned over and put down loosely on the area thus providing a walking and working surface while other tasks are completed.

Note: Boards should not fit tightly to wall frame. Allow up to 10mm gap between bottom wall plate and floor board. This gap would normally be covered by wall lining and skirting or kick board.

5 CONDITIONING: Boards put down loosely will be conditioning to the atmosphere of the area and tasks such as installing ceilings, painting exterior trimwork or cladding could be done if desired. Do not fix boards during sustained periods of wet or very dry weather - aim for "average" conditions.

6 **FIXING FLOOR:** Several possible procedures are as below.

METHOD 6A - For straight run flooring without intruding doorways, etc.

The first boards are turned over along the length of wall, and the first one complete length of flooring is nailed along the wall. Leave overall gap along wall plate but fix this first board in a slight curve, close to wall at each end, slightly larger gap at centre.

Continue cramping and nailing several boards each time along the whole length of the room. No firm rule can be quoted as how many boards should be cramped at one time but about 600mm overall width each cramp-up may be some guide. At each cramping leave out the nails on the last cramped board until the next batch is cramped up so that the T & G joints fit together more easily.

At about the centre of the room the boards should run straight and this should be checked by eye or stringline.

METHOD 6B - Where doorway intrudes as in sketch and existing flooring has to be matched such as when sanding and clear finishing is desired. The first board(s) should be located and fixed in the new doorway and lined up with existing flooring.

Subsequently, new flooring would be fixed moving away from first board to left and right as in Method A.

Note also that a better appearance is achieved if the new boards are keyed into the existing flooring. This procedure requires each alternate board in the existing floor at the new doorway to be cut back to the nearest floor joist (see sketch) and the new boards fitted into these spaces.

METHOD 6C - Where new doorway is required, such as in sketch below, and the new flooring is to be matched to the existing flooring. The first board should

be cut so as to fit into the grooves or over the tongues of the existing board floor, and cut out to fit into the doorway. The second board is similarly cut to fit the doorway but also may require ripping along the length so as to fit along the wall in the new floor area. These first few boards are cramped tightly and nailed in place, then fixing the floor proceeds as in Method A.

Note that in this Method 6C the normal floor joists may have to be supplemented under the two door frame studs by short joists or trimmer pieces onto which the new boards can be nailed, as shown in sketch. Cutaway drawings illustrating procedure for fixing new flooring for a room addition to existing structure.

Note: Internal lining, architrave and skirting fitted after flooring is fixed.

7 **FINISHING FLOOR:** With flooring nailed in place, nails punched, fix all wall linings and architectural trim work (architraves and skirting, etc.), electrical work, etc. can be completed.

After all this work, etc. is completed, the flooring can be finished. This would require one of these procedures:

(a) for covered floors: rough sanding using a powered floor sander machine; or

(b) for exposed decorative floors: fill all nail holes with coloured or stained wood putty then rough sand as in (a) but then finish with fine sanding to give a smooth finish.

Finally, apply selected clear timber floor finish.

TOOLS YOU WILL NEED

- Hammer and nail punch
- Carpenter's square and pencil
- Saws
- Stringline
- Chisels
- Flooring clamps (These can be hired in the larger metropolitan areas)

MATERIALS YOU WILL NEED

TIMBER

Selection of a particular type of T & G strip timber flooring would depend on whether the boards are to be fine sanded and clear finished (i.e. as a feature floor) or coarse sanded then carpeted where the new flooring is to be permanently carpeted, or covered with sheet vinyl or similar. You would also achieve an economical result with T & G sheet flooring particleboards or plywoods if the floor will be carpeted or otherwise covered.

You should discuss with your timber stockist what your needs are and the type of flooring available which would give you the effect desired.

HARDWARE

Nails: 50 x 2.8mm bullet head nails when standard thickness (19-21mm) flooring is used.

Putty: Hard setting filler for nail holes if flooring is to be clear finished or stained.

Supplied by

