

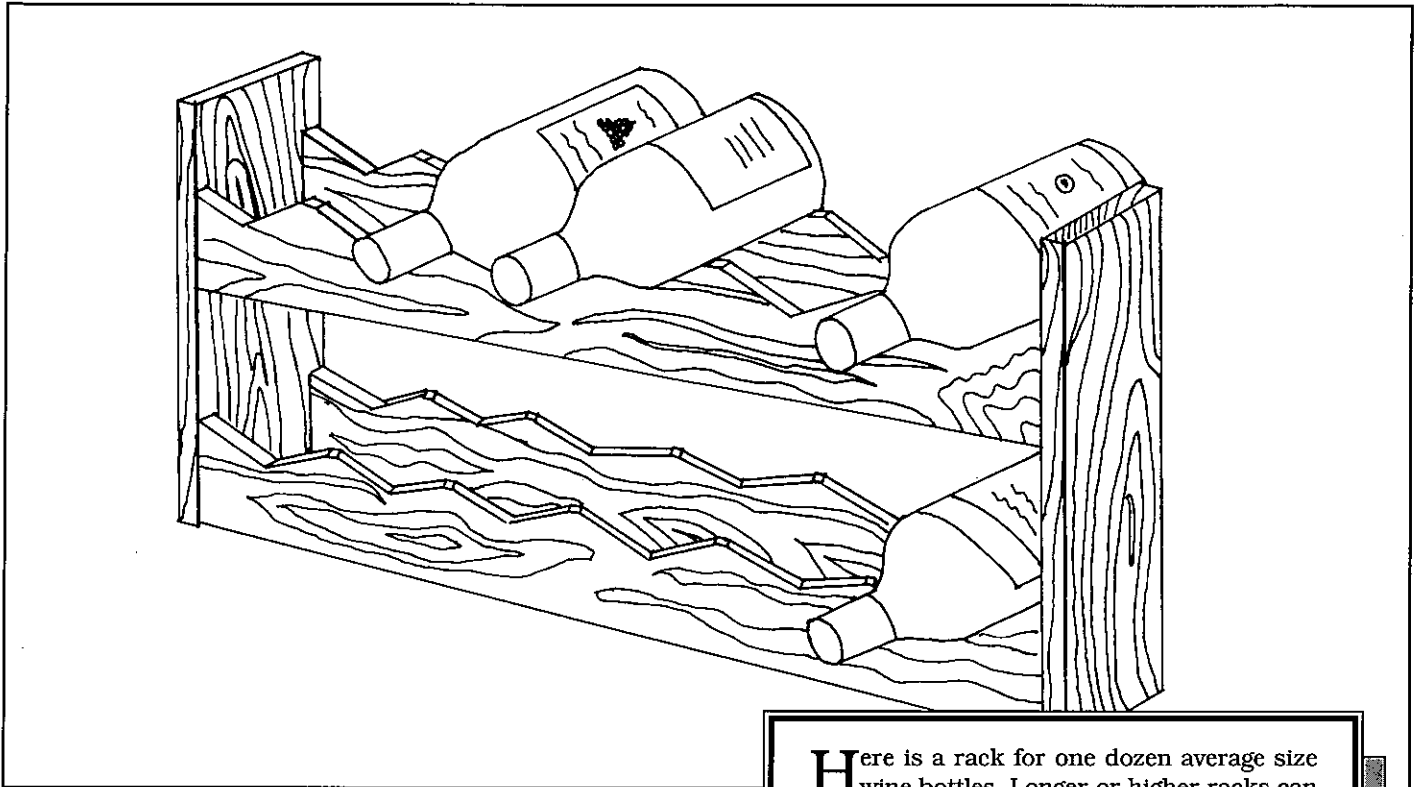

Wine Rack



Timber and Building
Materials Association
(NSW) Limited



Here is a rack for one dozen average size wine bottles. Longer or higher racks can be designed using spacing shown but some variation in timber thickness, width, etc., may be necessary.

TOOLS YOU WILL NEED

- Hand saw
- Hammer
- Nail punch
- Carpenter's mitre square and pencil
- Measuring tape or rule
- Drill and bits

MATERIALS YOU WILL NEED

TIMBER QUALITY*

For a decorative clear finished set up wine racks use appearance quality timber dressed all round (DAR). For a utility grade rack for the cellar use 'sawn' timber for economy.

TIMBER SIZES*

(Basic module 1 dozen bottles)
150 x 25mm x 600mm (2 pieces 300mm) sides
75 x 25mm x 2700mm (4 pieces 600mm) rack

HARDWARE

50 x 2.9mm bullet head nails
Sandpaper or electric sander

STEP BY STEP

- 1** Cut four rails 'A' from the pieces 75 x 25mm. Each rail to be exactly 600mm long.

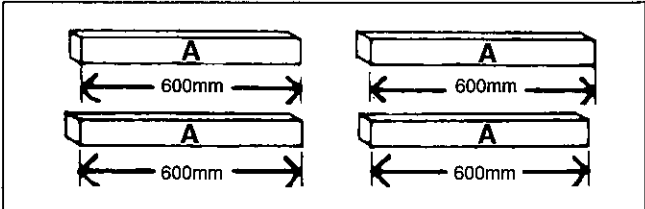

- 2** Mark out each of the four pieces 'A' as below. Drill six 6mm holes as shown in Step 2, then cut each triangular piece out using hand-saw or jig saw, cutting into the prepared 6mm holes. Smooth off each rail 'A' with sand paper or sander.

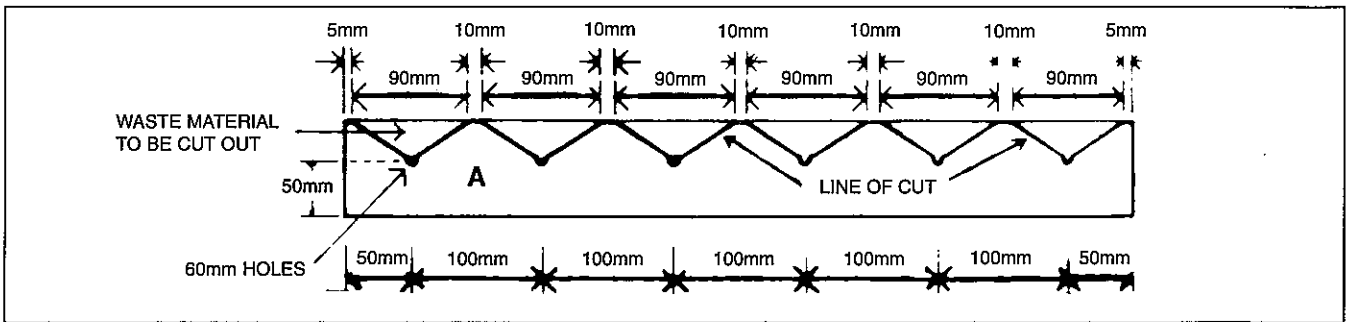

- 3** Cut two end pieces 'B' from the piece 150 x 25mm. Each piece to be exactly 300mm long.

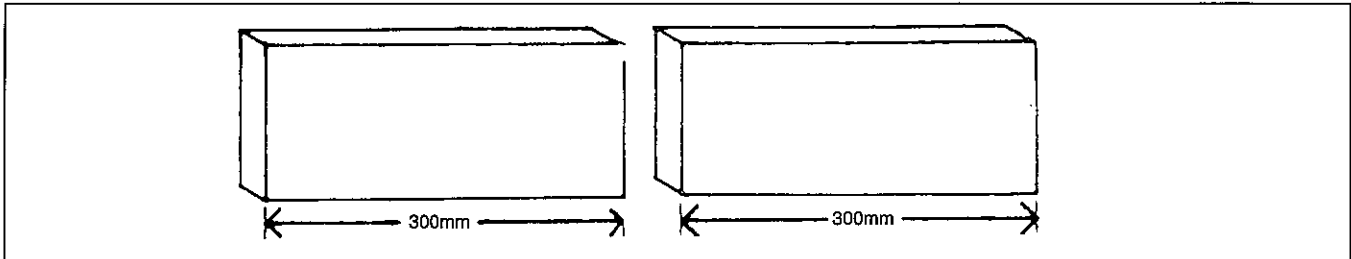

- 4** Attach rails 'A' to ends 'B' at spacing shown using two 50 x 2.8mm nails at each end. Punch nail heads.

Note: Pre-drill nail holes but locate to avoid timber splitting and penetration into bottle retaining space. Smooth down, fill nail holes, etc., stain, clear finish, paint, etc., as desired.

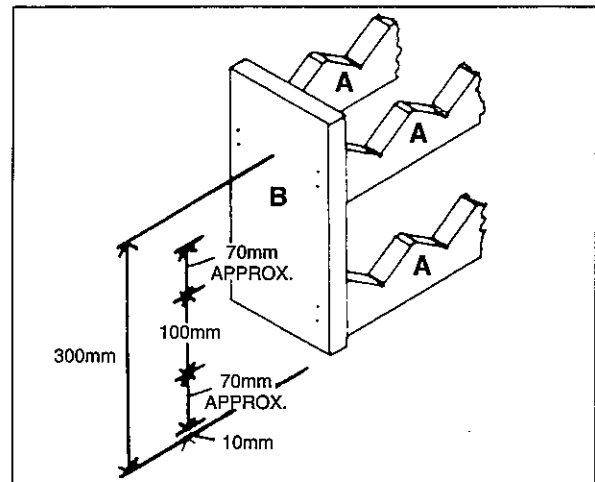

DESIGN VARIATIONS

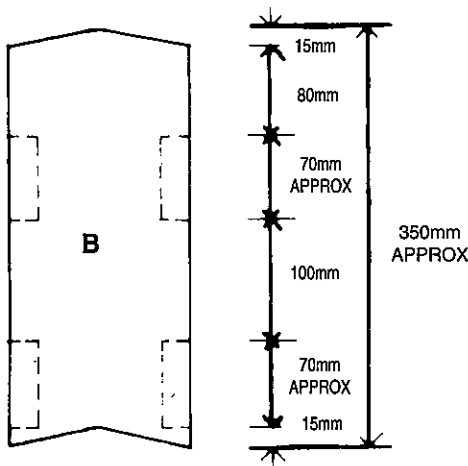

1. Demountable Rack: Use screw fastening instead of nailing so that rack can be disassembled as required

2. Stacking Racks: Cut two sides 'B' from a timber piece 150 x 25 x 900mm DAR and to shapes shown. Assemble as indicated using location clamp or clip.

CLAMPS ON INSIDE OF RACK, ONE EACH SIDE, SCREW FASTENED, MADE FROM THIN SHEET MATERIAL OR TIMBER 75 x 25mm

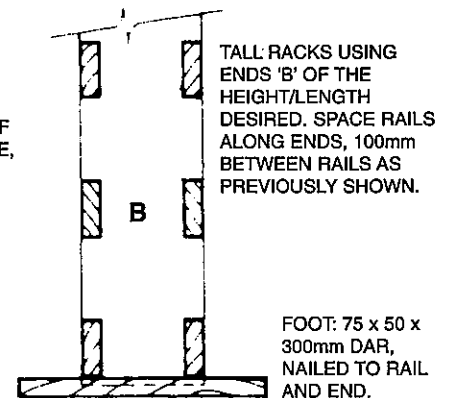

3. Tall Racks: Very tall racks could be unstable because of height. Use standard or racking design but add a 'foot' to each side of the rack depending on space available. Use an added 'foot' equal to about normal bottle length. Use, for example, one 'foot' each end, cut to 75 x 50 x 300mm DAR.

Supplied by