

Work Bench

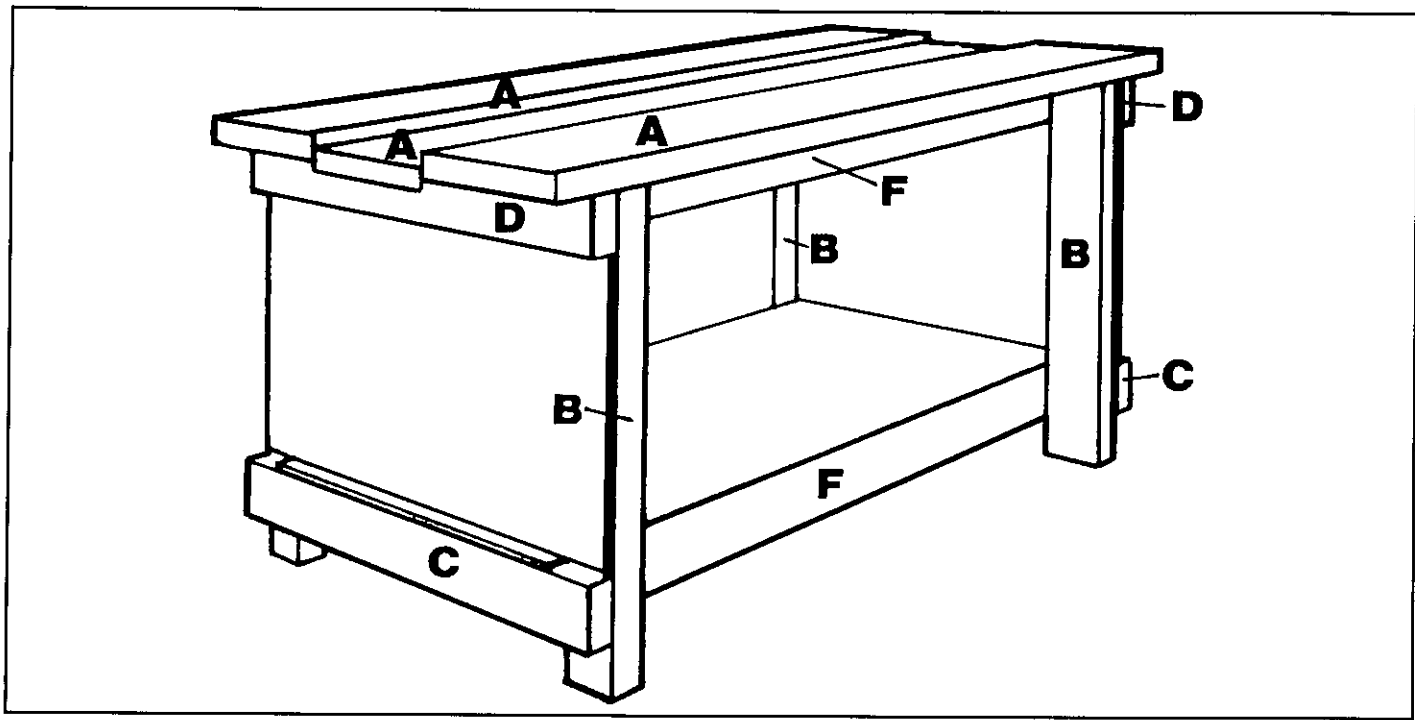

▼ **STEP BY STEP** ▼

1 Cut three equal length planks 'A' for top from 250 x 50 mm DAR

A diagram showing a rectangular plank labeled 'A'. A dimension line below it indicates a length of 1800mm. Below the dimension line, it says "3 REQUIRED".

2 Cut four equal lengths 'B' from 75 x 75mm DAR

A diagram showing a rectangular plank labeled 'B'. A dimension line below it indicates a length of 810mm. Below the dimension line, it says "4 REQUIRED".

3 Cut five crossbars from the piece 100 x 50mm DAR

Three diagrams showing crossbars labeled C, D, and E. Crossbar C is 700mm long, 2 required. Crossbar D is 700mm long, 2 required. Crossbar E is to be cut to fit between rails, 1 required.

4 Cut four equal length rails 'F' from 100 x 50mm DAR

A diagram showing a rectangular rail labeled 'F'. A dimension line below it indicates a length of 1500mm. Below the dimension line, it says "4 REQUIRED".

5 Drill two 12mm diameter bolt holes in cross bars 'C' and 'D'

A diagram showing a crossbar labeled 'C & D'. It has two bolt holes. The distance between the holes is 700mm. The distance from each hole to the nearest end is 35mm. A dashed line indicates the 'CENTRE LINE'.

6 Cut recess in 'D' to take centre top plank. Saw cut then chisel out waste.

A diagram showing crossbar 'D' with a recess cut into its top surface. The recess is 20mm deep and 235mm wide. The distance from the recess to each end is 235mm. The width of the recess is labeled "WIDTH OF 'A'".

Tools you will need

- Saw
- Carpenter's Square
- Spanner
- Hammer
- Wood brace or electric drill
- Rule or tape
- Pencil
- Drill bits
- Chisel
- Screwdriver

Materials you will need

TIMBER

Hardwood or Softwood

Hardwoods are more resistant to damage (e.g. hammer blows) but are hard to work and heavy. Softwoods are lightweight easy to work but are easily scratched and damaged.

- 250 x 50mm DAR, 3 pieces 1800mm
- 75 x 75mm DAR, 4 pieces 810 mm
- 100 x 50mm DAR, 4 pieces 1500mm
- 100 x 50mm DAR, 5 pieces 700mm
- 9mm dowel, 1 piece 300mm for plugs

Sheet Material

- 1800 x 900 x 6mm Plywood or
- 1800 x 900 x 12mm Particleboard
- 3 pieces required

HARDWARE

- 16/125 x 9mm cuphead nuts, bolts and washers
- 30/75 x 4.9mm wood screws
- 50/2.8 x 50mm flat head nails
- 8/3.2 x 75mm bullet head nails
- Optional vyce, engineer's or woodworker's

- 7 Assemble end frames:** Locate cross bars 'C' and 'D' on legs and using predrilled holes as guide, drill bolt holes through legs. Make up two end frames, bolt loosely.

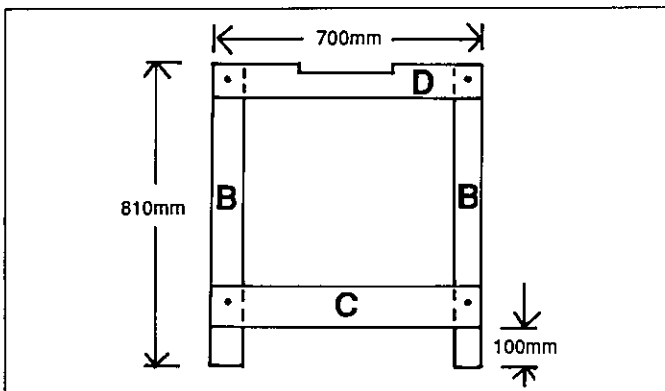

- 8 Fit end brace sheet:** Cut the 6mm ply or 12mm particle board for brace as shown. Square up leg assembly and nail sheet material at 150mm centres using flat head nails. Tighten bolts.

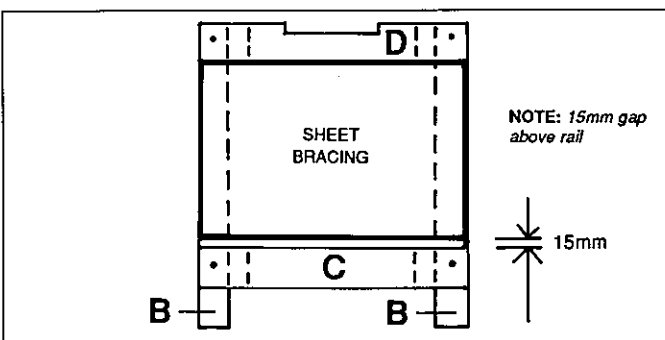

- 9 Attaching long rails:** Drill bolt holes through front and rear legs at top and bottom so that holes clear leg bolts. Locate rails in position and, using holes as guide, drill through rails and fasten with nuts and bolts. Tighten loosely.

- 10 Fitting floor bracing:** Cut sheet material to make shelf or bench. Note this shelving fits through gap under end frame brace material. Square up frame and nail flooring to full length of rails and to cross bars. Tighten rail bolts.

- 11 Attaching backing brace:** Cut sheet material to fit as a back brace, to be attached to the back face of the rails and between legs. Check squareness of frame, adjust if necessary, nail back brace in position, using flathead nails at 150mm centres, then tighten bolts.

- 12 Cut centre bar 'E' to size and locate and cut recess to receive top plank as in step 6. Nail in place at centre of rail using four nails per joint. Bench framework should look as shown in diagram.**

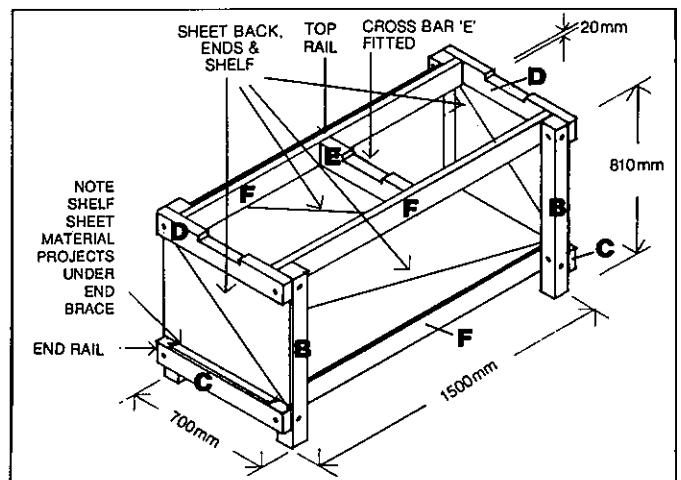

- 13 Fitting bench top:** Planks 'A' are fitted to framework evenly spaced as shown, using sunken screws, with screw heads concealed but covered by dowel plugs as shown. Use three screws in each plank at both ends and two screws at centre cross bar.

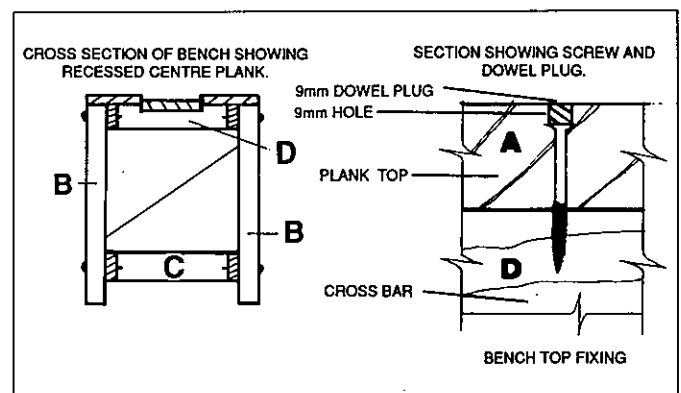

- 14 Fit desired woodworker's or engineer's vyce as instructed by manufacturer.**

Disclaimer: While the Timber and Building Materials Association (NSW) Limited (TABMA) and its members believe this publication is an invaluable guide to this project, the Association cannot guarantee that every statement is without flaw. Therefore, the Association and its members hereby disclaim all liability for errors or omissions of any kind, whether they be negligent or otherwise, or for any loss, damage or other consequence which may arise from any person relying on information stated in this publication.

This brochure was prepared with the assistance and co-operation of the Timber Development Association NSW Ltd.

For further advice telephone the TDA Timber Advisory Service on (02) 9360 3088

Copyright Owner:
Timber and Building Materials Association (NSW) Limited